

# Template Miniatures

by Alexandre Karadimas

Make your own 1:64 miniatures with common household tools and materials

## Cruiser tank

All models in this booklet are historically accurate.

Cruiser Mk IV



- Realistic ventilator grilles
- Very detailed: hatches & handles, air filters, exhausts, smoke generators, antenna, headlight, searchlight
- Removeable pennant on antenna for identification



Option: mantlet spaced armour on Mk IV turret

Cruiser Mk III

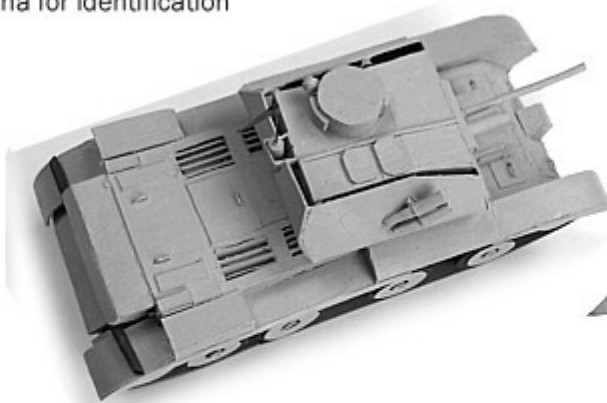

The gun barrels can be glued between  $-15^{\circ}$  and  $+20^{\circ}$  of elevation. The turret rotates freely.



Download this booklet and others for free from <http://www.template-miniatures.com>  
Visit the Youtube channel: <https://www.youtube.com/@ToothpickMiniatures-wl7gf>

Booklet 10 - Cruiser tank Version 1 - March 2026

## Tooling, Materials and Production aspects

**T01** Tools required for all Toothpick Miniatures designs

Pin Ø 0,6 mm  
Pin Ø 0,4 mm

Pair of nail scissors

Small "snap-off blade" utility knife

Pair of thin pliers with a wire-cutting capability

Piercing board with a Ø 4 mm hole drilled through it, larger holes are useful

(1) Mechanical pencil Ø 0,7 mm or less (2) Roller pen (even a depleted one) to draw folding lines.

(\*) Use a toothpick to apply glue to parts

(3) Set square in metric (4) Stationery hinge clips (5) Household glue, in liquid or gel form (\*)

**T02** Tools required for this design

Ø 3,6 mm nail, or object of a comparable diameter (see Step P02 page 3).

(1) Metal file to deburr wire after cutting. (2) Permanent marker to mark metal wire.

Recommended: a segment of a transparent ruler (3). (4) This ruler of the "aleph.pro" brand has matching measures on both sides, making it a small set square.

Always cut downwards on a cutting board and never towards any part of your body.

Please don't cut yourself.

Cutting board: a flat piece of wood, MDF, thick plastic or any other suitable material

**M01** Cardboard used in packaging is technically called "thin cardboard". We will distinguish between :

- "very thin" cardboard, as can be found for instance in biscuits packaging;
- "regular" 0,4 mm cardboard found for instance in tissue boxes;
- "thicker" 0,5 mm cardboard found in sturdier breakfast cereal boxes.

Glue works better on the **porous** side of cardboard packaging. The smooth, printed side is better suited to be painted over. Glueing two smooth sides together doesn't work well.

Accumulate several layers to measure the thickness. Here, the difference between regular and very thin cardboard is quite visible.

**M02** Double Wire Clips can be found in bread packaging for instance, they have very malleable wire. DWC plastic can be transformed into parts that match the wire perfectly.

1 mm  
0,45 mm



Plastic tubes

If you have double wire clips of slightly different thickness, sort them out and use only the thinner ones for this project.

The basic car miniature will require at least three double wire clips, some special versions even more.



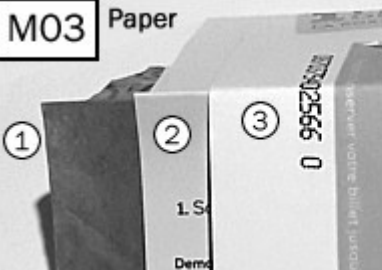

**M03 Paper**

(1) **Thin Kraft paper** can be found in paper bags for fruits & vegetables. (2) You can use envelopes for **regular paper**. (3) **Rigid Paper** can be found for instance in train tickets and magazine covers, it can retain its shape when folded.

Rigid Paper is made of a single layer (4) whereas cardboard (5) is made of several layers that come apart when bent.

**M04** (1)  $\varnothing$  0,3 mm **thin wire** is typically sold as "florist wire" or "jewelry wire".  $\varnothing$  0,25 mm thin plastic-wrapped "freezer" wire (2) can substitute for thin wire.

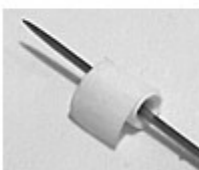
This design uses paper stems of ear cleaning swabs ("Q-tips"). Some varieties have a **hole** in their center (3). Note that different varieties have been marked differently (4) so that the workshop's materials supply remains manageable.

(5) Q-tips stems are a tight roll of paper. Conical shapes can be made by pushing in the center with a nail or a similar object.

Some parts have a simple design and are best drawn in batches, using a ruler. Several examples are shown in the Steps illustrations.

Other parts have a complex design, which would be

too time-consuming to draw from scratch. In these cases we will first make a **template**, a piece of cardboard with all the markings needed to replicate these parts, as well as indications to modify and position them precisely afterwards.

**P01 How to make templates**

1. On a white piece of cardboard, draw a rectangular frame and write the measures on all sides.

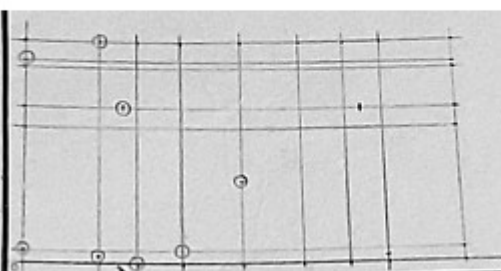

2. Use these marks as a grid to position points of the template. Draw the template.

3. Pierce the points as indicated then cut to shape.

4. Label the template. Draw the location of the folding lines with a distinct colour, also mark "special" dots.

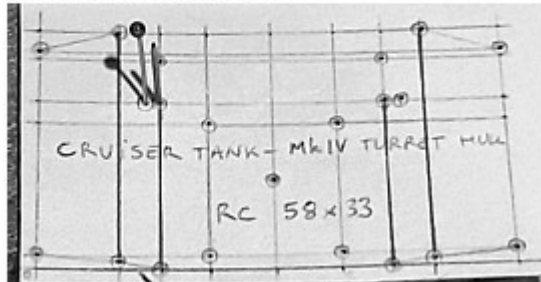

First pierce with the  $\varnothing$  0,4 mm pin then use the  $\varnothing$  0,6 mm pin and wiggle it so the  $\varnothing$  0,7 mm graphite tip of the mechanical pencil can get through.

Most templates are on the central pages (pages 6 & 7)

**P02 How to make a  $\varnothing$  3,6 mm paper cylinder:** Cut a 70 x 20 mm piece of regular paper. First roll it around a toothpick to give it a round shape. Unroll it then gradually glue it tightly to the toothpick then around itself. (1) Check the diameter. (2) Write the label on the cylinder.

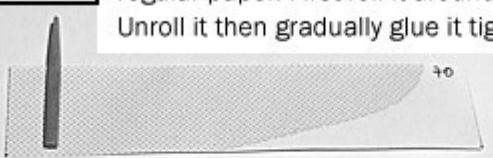
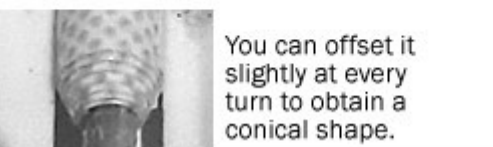



You can offset it slightly at every turn to obtain a conical shape.

An inexpensive plastic calliper is sufficient for these projects and highly recommended if you want to develop your own designs.

## Part A - Cruiser Mk III & Mk IV hull

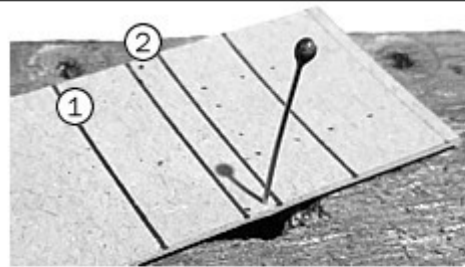
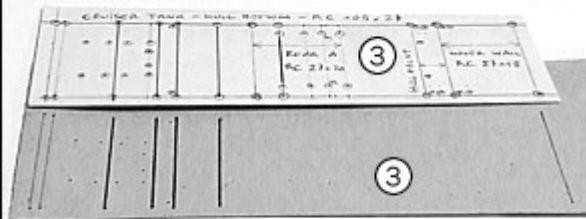
### A01 Hull bottom template



Notice the holes in this board: they make perforations easier.

(3) Notice the template integrates three parts templates that weren't used on the "hull bottom" part.

Use the template to mark the dots on the cardboard. Start by connecting the vertical lines with a pencil, even the fold lines.

(1) Use a ball pen to accentuate the fold lines. (2) To simplify the template, only one of the two dots necessary for the front towing lugs has been defined. Perforate this dot and its counterpart should be.

### A02 Parts templates integrated to the "Hull bottom" template

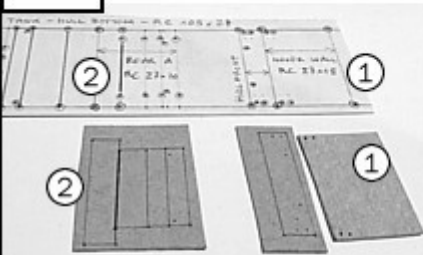

(1) You will need two "inner wall" parts, use thicker cardboard if available. See Step A05 page 5 before perforating.

Cut parts "Rear A" (2) and "Rear B" (3) into shape. Cut away the two small panels from "Rear A" (4) and perforate one of them.

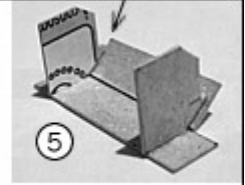
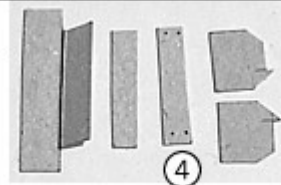

**Note:** some parts need to be of the exact same width as the "hull bottom" part. The easier way to ensure they are was to integrate their templates into the "hull bottom template".

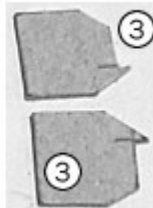

(5) Glue the two "Rear B" parts on the T-shaped "Rear A" so the folded part matches.

(6) While the glue is still fresh, immediately glue to the "inner wall" part, align the parts to the bottom and on the sides.



### A03 Hatches and handles

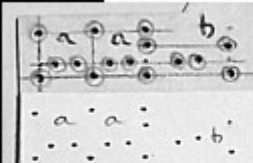

Label each hatch part before cutting.

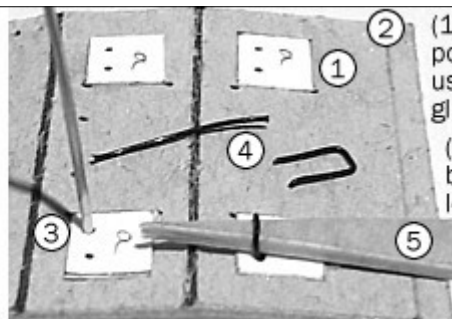

(1) Glue the "a" hatches to the hull part using the positioning dots. The dots for the handle point forwards, use the positioning line (2) as a reference. (3) Once the glue has hardened, perforate the handle dots.

(4) Cut 10 mm bits from  $\varnothing 0,3$  mm floral wire and bend them in a "U" shape so they can be inserted to look like hatch handles.

(5) Cut double-layer pieces of cardboard into sharp triangle shapes. These will be the spacers for the handles.

### A04 Handles and towing lugs

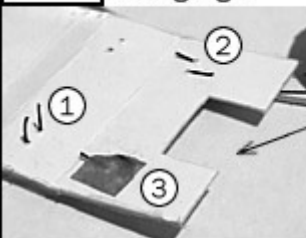

(1) Make sure the spacer is in place when the handle part sticks out.  
 (2) Bend the ends at a right angle from the handle (so the handle doesn't pivot). This also avoids interference with the 12 mm wide "Front support" part (see Step A10).  
 (3) Glue a piece of thin kraft paper on the bent handle bits to keep the handle in place.

**Note:** the hull part shown here is for the turretless version (see Booklet n° 14).

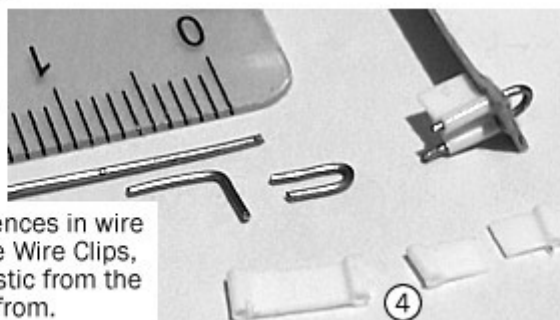

For the **towing lugs**, cut 10 mm bits of DWC wire, deburr the ends. Bend the bits in a "U" shape so they can be inserted through the holes.

Use the DWC "sheath" parts (4) to hold the towing lugs into place.

Use pliers to hold the wire in place while slipping the DWC sheath onto it.



**Note:** there can be differences in wire diameter between Double Wire Clips, make sure to use the plastic from the DWC the wire also came from.

### A05 "Hull sides" template



(1) Cut the template at its bottom line. (2) The template has been cut out where the curves are. (3) Start by drawing a line, then align the template bottom to it.

White circles: perforate the dots for the sprockets, the road wheels and the idlers.

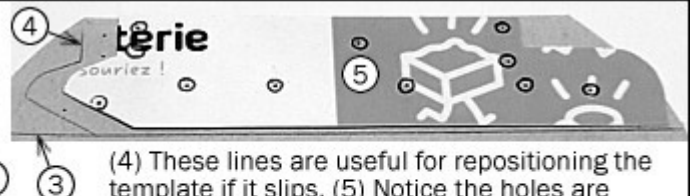

(4) These lines are useful for repositioning the template if it slips. (5) Notice the holes are marked on the reverse side of the template.



### A06 Cut the Hull top part as depicted below.

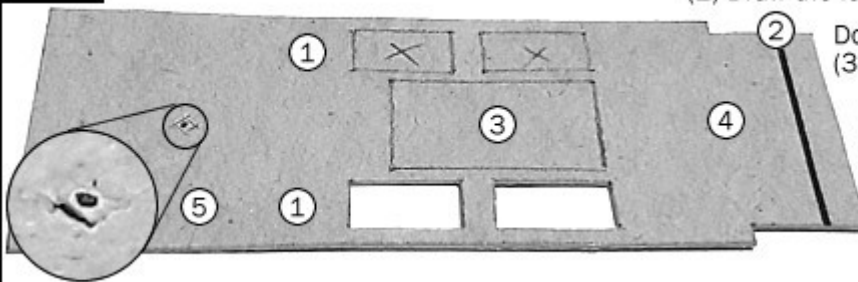

(1) Cut the four holes for the ventilation grilles.  
(2) Draw the fold line with a ball pen.

Don't install either the "c" and "c+" hatches (3) or the "Engine hatch" (4) yet.

(5) Cut a square hole, its sides about 1 mm long, around the turret axis dot.

For the **turretless** circular hole, use a 10,5 mm compass centered on the turret axis dot. Cut out the hole at this stage.

### A07 Ventilation grille jig, grille parts

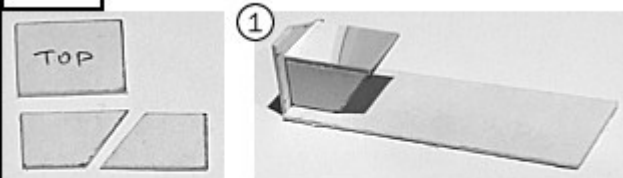

Use the dimensions provided page 8 to make the parts for the jig. Glue them to a piece of cardboard, glueing an additional piece of cardboard on the back (1) improves stability.

For each grille, cut: four 8,5x4 mm piece of rigid paper as well as, two 8x4 mm and one 8x2 mm pieces of double-layer cardboard. (2) You can reuse snippets from the outer road wheel production process (see Step D01).

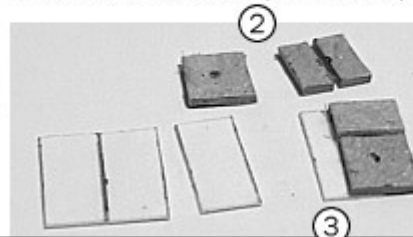

Glue the 8x4 mm and the 8x2 mm parts on rigid paper parts, leaving 2 mm free (3).

The two assemblies with the 8x4 are the lower parts.

### A08 Grille assembly

Apply glue to the cardboard of one of the lower parts, and put the second lower part on it. While the glue is fresh, press the assembly against the grille jig, as depicted (1), to get the correct angle.

Make sure the "blades" are aligned on both sides.

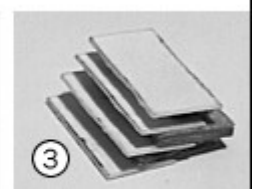
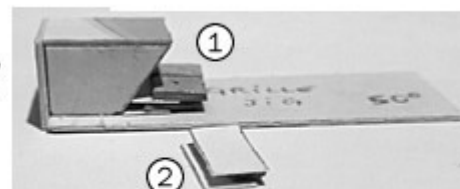

Follow the same procedures with the two upper parts (2), wait for the glue to harden. (3) Glue the two assemblies together, without using the jig: check visually instead.

### A09 Grille assembly



(1) Cut two cardboard pieces about 8x4 mm in size (they can be leftovers), for each apply glue to their porous side and below one of their longer sides.

Place the upper side of "Hull top" part on your work surface, make sure it is flat.

Position the grille assembly inside the hole and against the work surface, glue the two cardboard sides to it and to the "hull top" part. Leave 1 mm free for the "hull sides" parts.

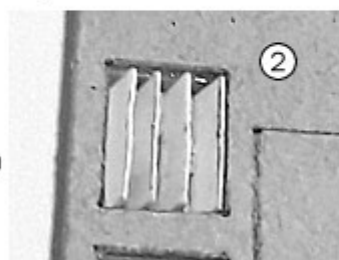

(2) While the glue is still fresh, turn the "Hull top" part over and check if the grille is well aligned and does not protrude from the hull top's surface.

(3) Notice the hole for the turret axle has been widened with a toothpick.

### A10 Hull assembly - Part 1



Fold the "front support" part in three, glue it behind the first fold on the "Hull bottom".

Use the "Hull bottom" template front to make a folded inner spacer part (1).

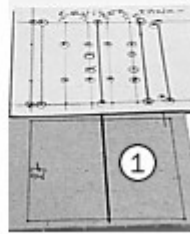

First glue the rear assembly (2) over the "Hull bottom" part, then the "Sides" parts (3), that are aligned (4) to the rear assembly. Glue the "inner spacer" (1) between the sides. Leave enough room for the turret axle (use the "hull top" part to locate it).

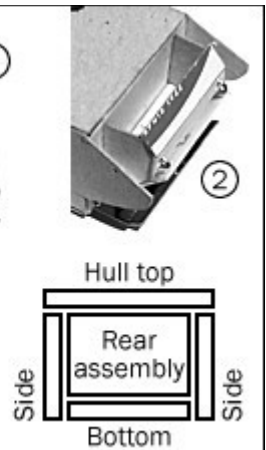

### A11 Hull assembly - Part 2

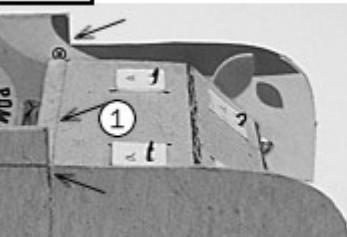

Apply glue on the top sides of the "front support" part. Apply glue to the sides of the "Hull bottom" front parts. Fold them over the "front support". Align the positioning line (1) to the front corners of the "Sides" parts. Maintain the assembly together until the glue has hardened.

(2) The "Hull front" part has been designed **deliberately too high**, you will have to adjust it **manually**. Measure the correct height then cut **before** installing the towing lugs and glueing.

*The height of this part cannot be defined accurately: tolerances of too many parts have added up, as well as possible differences in the thickness of materials.*

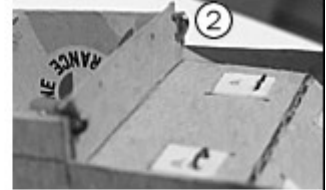

### A12 Driver box

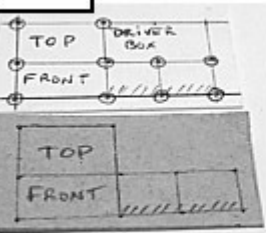

Label the "top" and the "front" parts.



The height of the "driver box" parts also has to be adjusted manually. Compare them to the adjusted "Hull front" part.

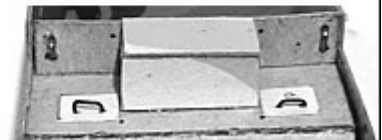
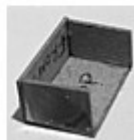
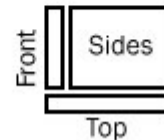

### A13 Hull top assembly

Glue the c, c+ and engine hatches, perforate them and install handles, following the same procedure as on Step A03.

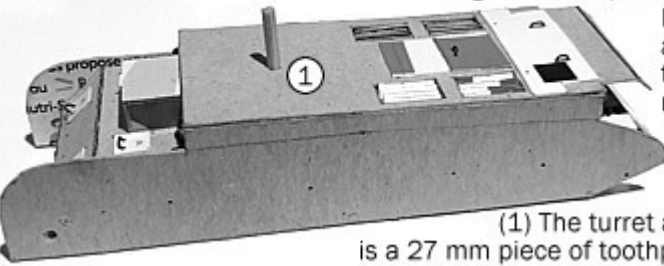

(1) The turret axle is a 27 mm piece of toothpick.

Note that the engine hatch is aligned with the rear notches. Glue the "Hull top" assembly to the hull, make sure there are no gaps.

Glue them underneath the rear overhanging part, against the rear wall and glue the angled flap (2) to them.



Cut the "Exhaust sides" parts.



### A14 The mudguards need manual adjustment in the front (1).

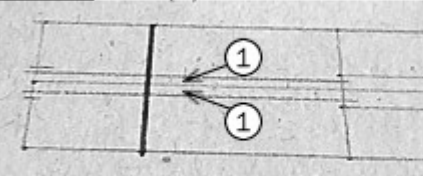

Note: if the "Sides" parts are not straight, leave some materials and trim it off using nail scissors.

Trim these parts gradually until the mudguards sit flush over the "Side" part (2).

(3) Give the ends a round shape past the fold line.

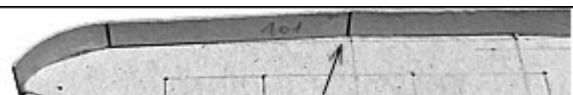

The mudguard is slightly folded.

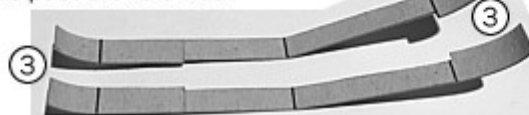

### A15 Cuts to the hull front

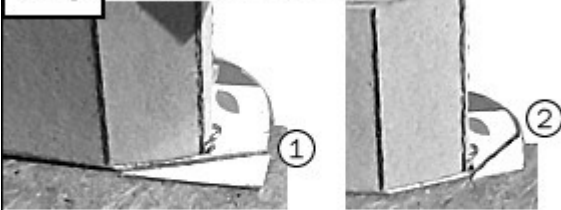

(1) Cut the "Side" part along the hull lower front angle.  
 (2) After having glued the mudguards, cut between the mudguard and the lower hull.

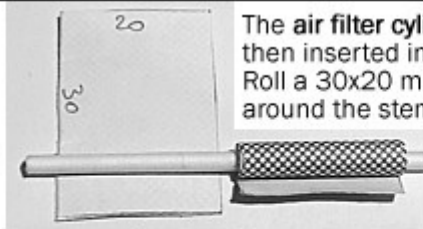

The air filter cylinders are painted separately then inserted into the "rear box" assemblies. Roll a 30x20 mm piece of regular paper around the stem of a Q-tip, glue the final part in order to obtain a cylinder 3 mm in diameter.  
 Cut the 20 mm cylinder into two 10 mm cylinders, glue their ends to pieces of regular paper, trim the excess.

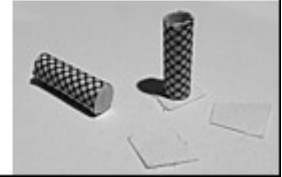

### A16 Rear boxes

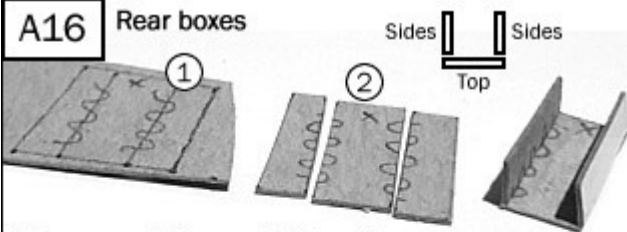

This assembly has a slight angle. To make it easier, the sides that are glued onto the top are marked (1) and the end that is slightly shorter is also marked with an "x" (2).

Glue the assembly to the mudguard and the side, align it with the rear of the hull. Notice where the "x" position should be.

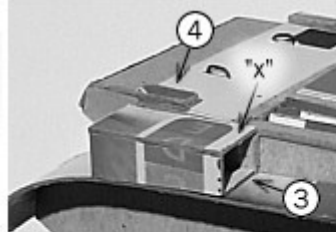

(3) Glue a 5x1 mm piece of cardboard to the front, but not yet to the rear, so the air filter can be inserted after painting (see page 10).

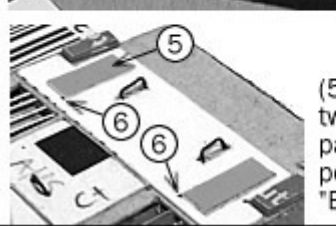

(4) Glue two 5x2 mm pieces of double-layered cardboard to the sides of the "Engine hatch".

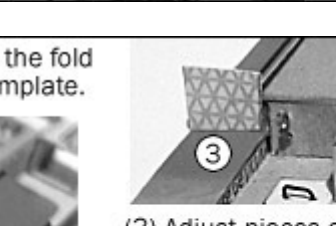

(5) For the "b" hatches, make two 8 x 3 mm pieces of rigid paper, glue them using the positioning dots (6) on the "Engine hatch".

### A17 For the front boxes, it is more precise to draw the fold lines on a piece of rigid paper than using a template.

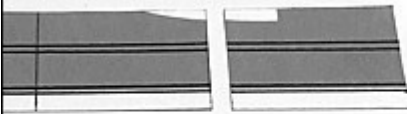

(1) Fold each fold line precisely. (2) Glue to the side and to the mudguard. Use a toothpick to reach inside.



(3) Adjust pieces of regular paper to the ends (front and rear) of the front boxes and glue them.  
 (4) Trim the excess.

### A18 Headlight & vision ports

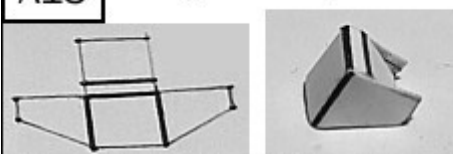

Cut and fold the headlight part from rigid paper as depicted above. Trim the excess on the rear wings. Glue to the front using the positioning dots (1).

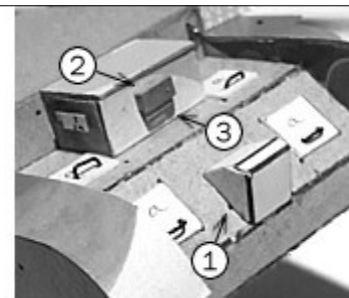

(2) Driver port armour, double-layer cardboard, 3,5 x 2 mm  
 (3) Driver vision port, rigid paper, 3 x 1 mm.



The side vision ports (rigid paper, 3,5 x 2 mm) are vertically aligned with the mudguards.



### A19 Final drive cylinders

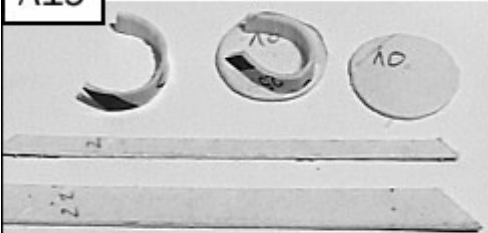

Use the M or the S compass to draw Ø 10 mm cardboard disks. Use 2 mm strips of cardboard as spacers.

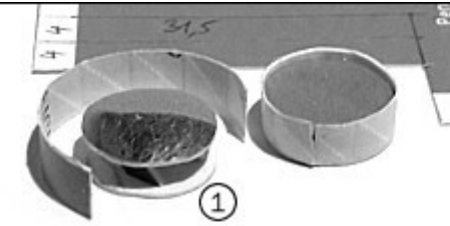

Glue the disks as depicted (1). Make 31,5 x 4 mm strips from rigid paper (preferred) or regular paper, give them a round shape, apply glue then glue to the wheel assembly. (2) Glue the cylinders against the rear assembly, not against the "Side" part.

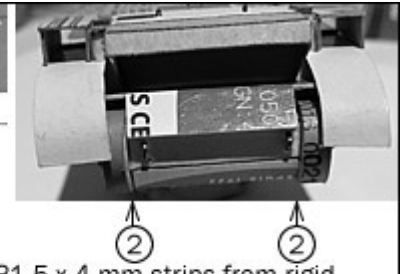

**Cruiser tank**  
**Templates**  
**Scale 1:64**  
**Page 1/3**

+ Pierce for 0,7mm

⊕ Special purpose

—|— Folding line

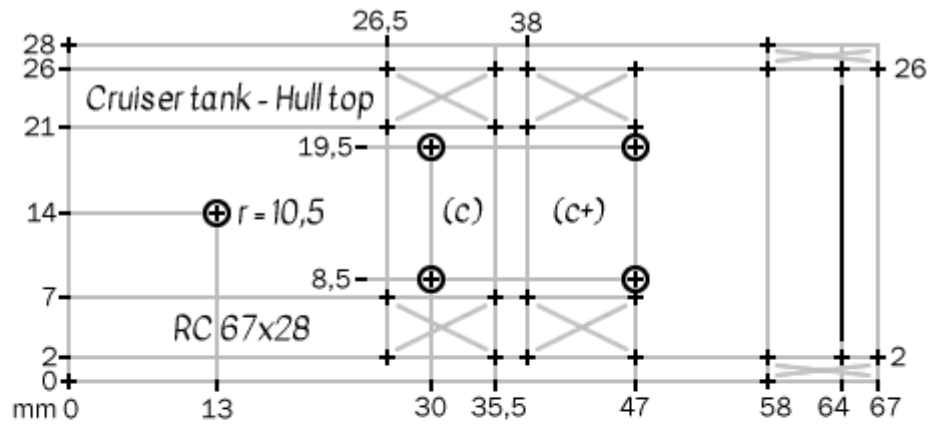

RC: Regular Cardboard  
 RP: Rigid Paper

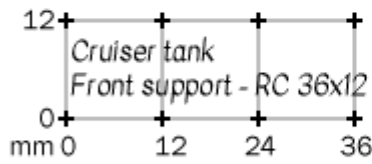

Headlights - RP 15x10

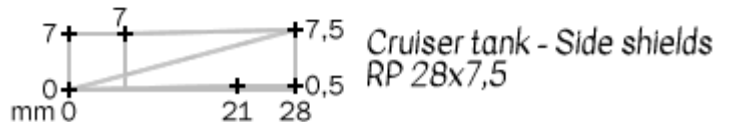
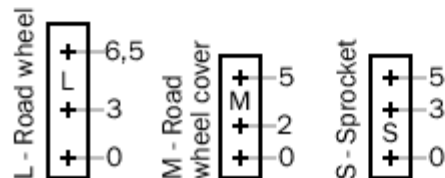
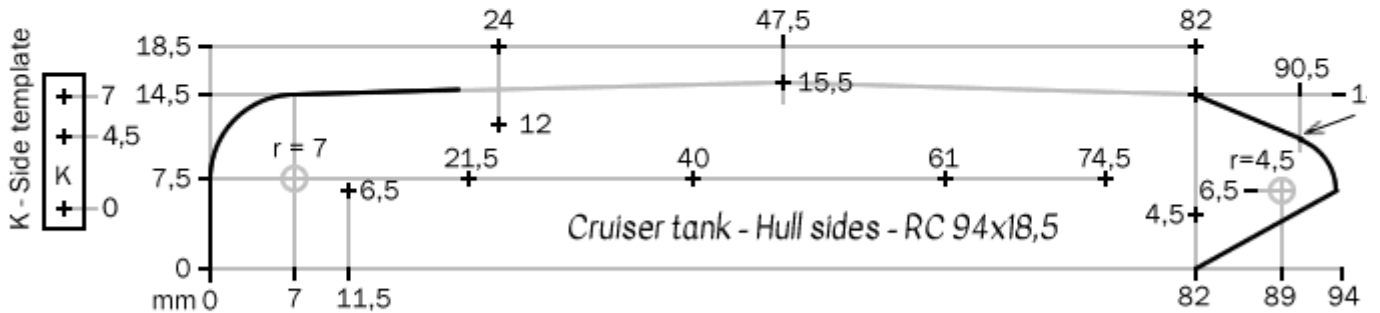
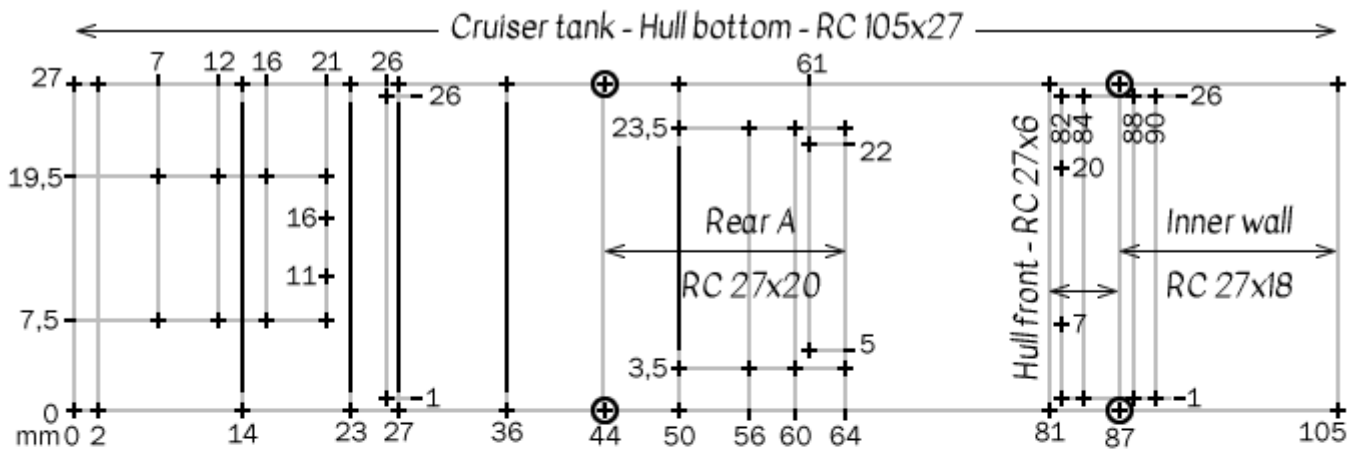
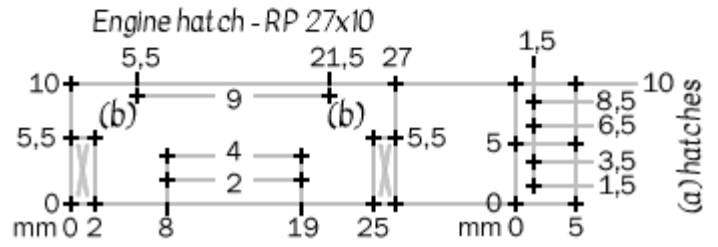
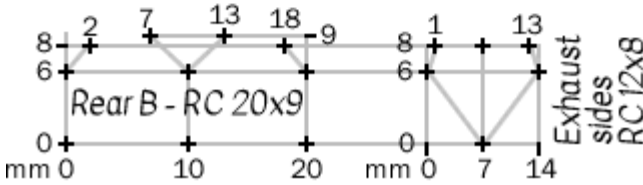
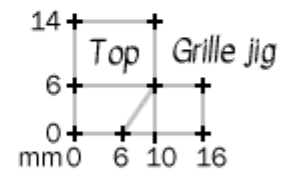
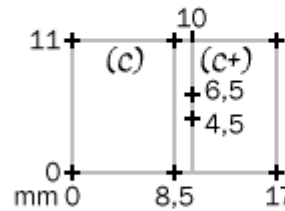
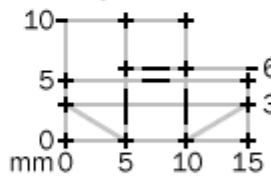

Diagrams on this page are not all at the same scale

**Cruiser tank  
Templates  
Scale 1:64  
Page 2/3**

+ Pierce for 0,7mm

⊕ Special purpose

—| Folding line

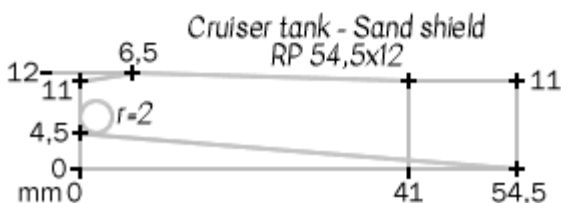
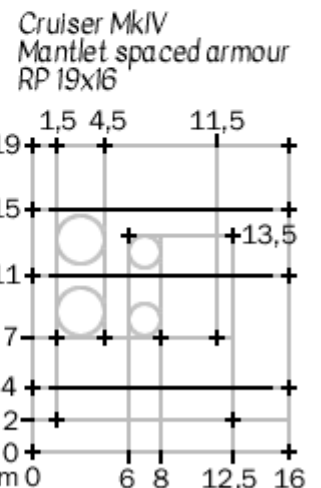
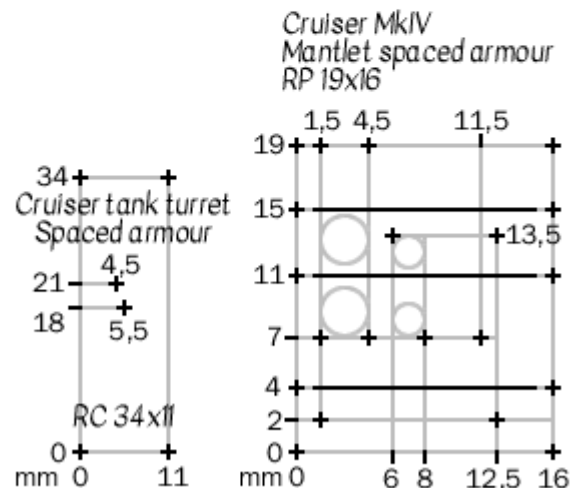
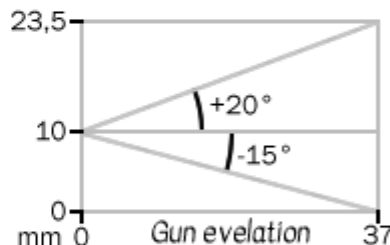
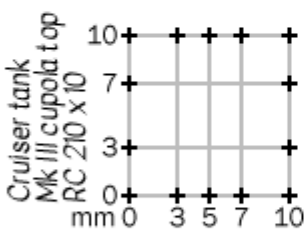
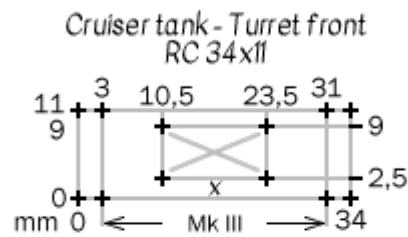
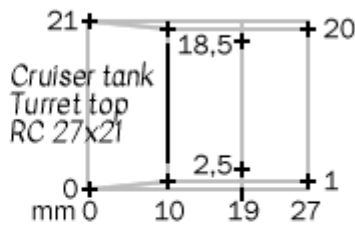
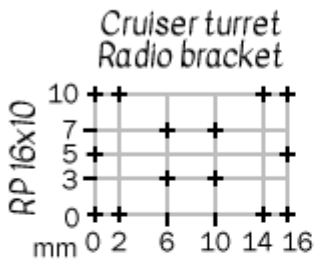
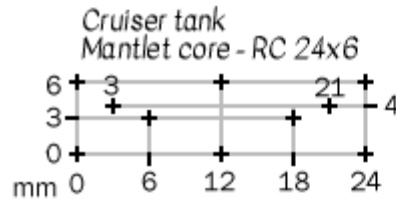
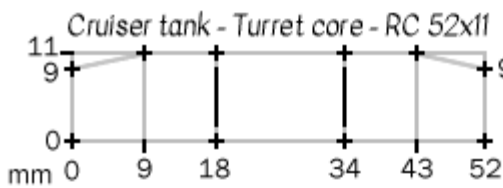
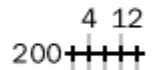
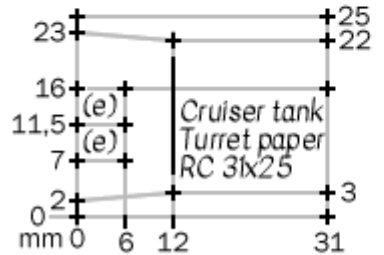
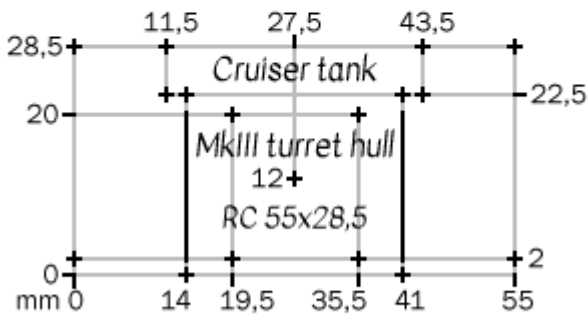
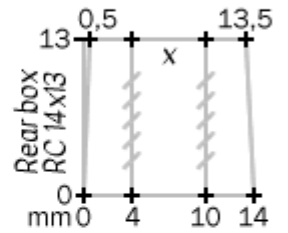
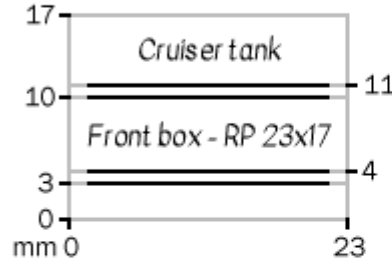
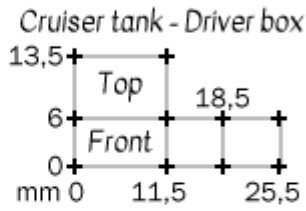
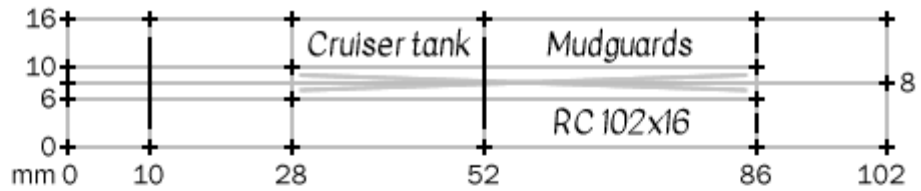

Diagrams on this page are not all at the same scale

**Cruiser tank  
Templates  
Scale 1:64  
Page 3/3**

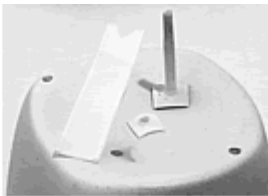

For the paint stand, perforate a plastic up with a  $\varnothing 2$  mm drill bit. Perforate DWC plastic and use it on both ends of a shortened toothpick to secure it into place.

**Painting:**

First spray a base layer of the parts. Oil paints of the inexpensive "Pebeo XL" brand were used here.

**Desert yellow** base colour is "Yellow Ochre" (n° 20) mixed with white.

**British / Soviet green** base colour is "Green Earth" (n° 44) mixed with a neutral grey, then with a slight touch of black. Proceed gradually.

**Light grey** is used for the air filters and the inside of the searchlight. **Medium grey** is used for the tracks.

Optional: "Burnt Sienna" is used for the exhausts.

- + Pierce for 0,7mm
- ⊕ Special purpose
- | Folding line

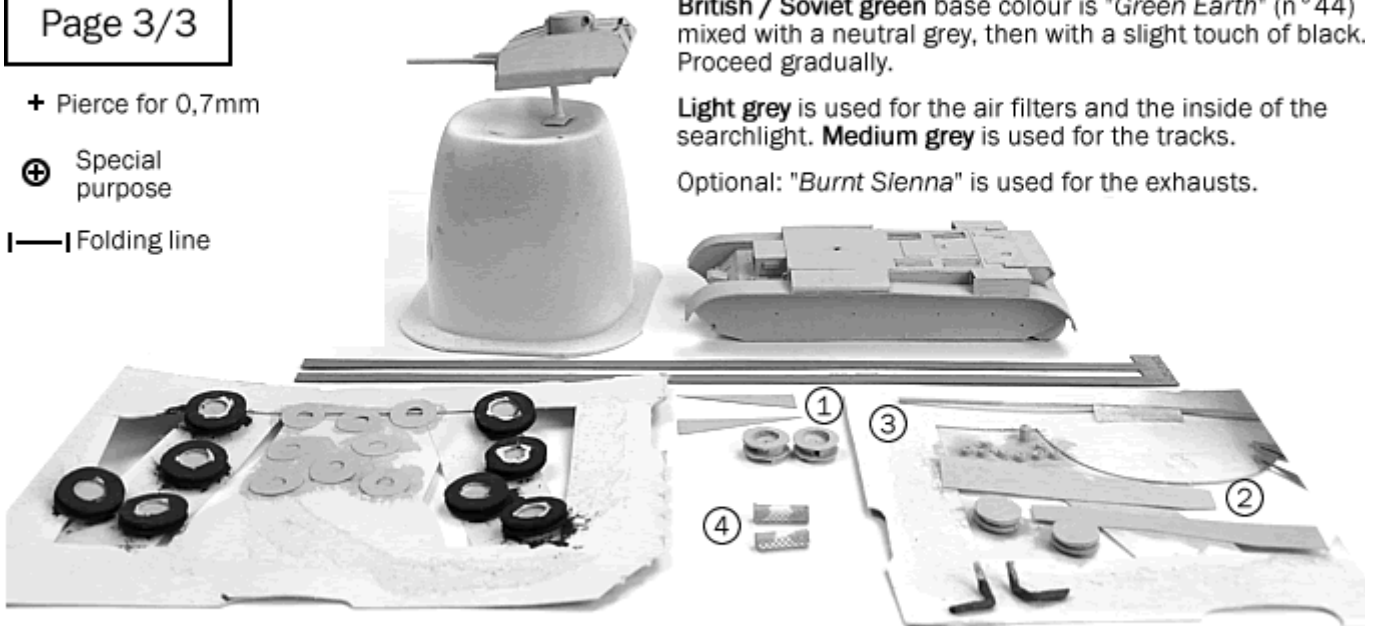

Stick the wheels to adhesive tape for painting, as depicted. The road wheels are on a separate tape, they will be painted in **dark grey**. The road wheel covers, the idlers and the sprockets are painted in the **base colour**.

(1) Make sure the side shields are mirrored when painted, there is one for each side for the desert version and two per sides for the european theater version. (2) Make sure the sand shields are also mirrored.

(3) Paint an extra 1 mm strip of cardboard, to be cut in 4,5 mm bits and used to close the two rear boxes once the air filters have been glued inside them. (4) Only the end of the air filters will be visible after installation.

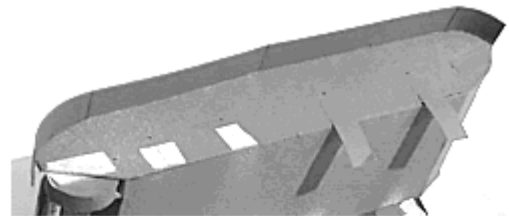
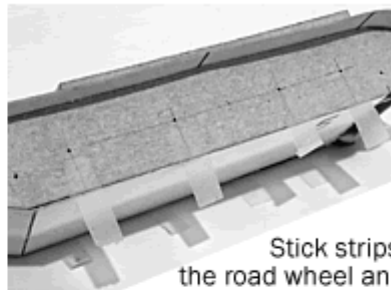
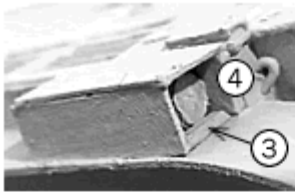

Stick strips of adhesive tape below the positioning dots for the road wheel and to the side of the idler & sprocket dots. This prevents the paint to reach the porous areas where the wheels will be glued.

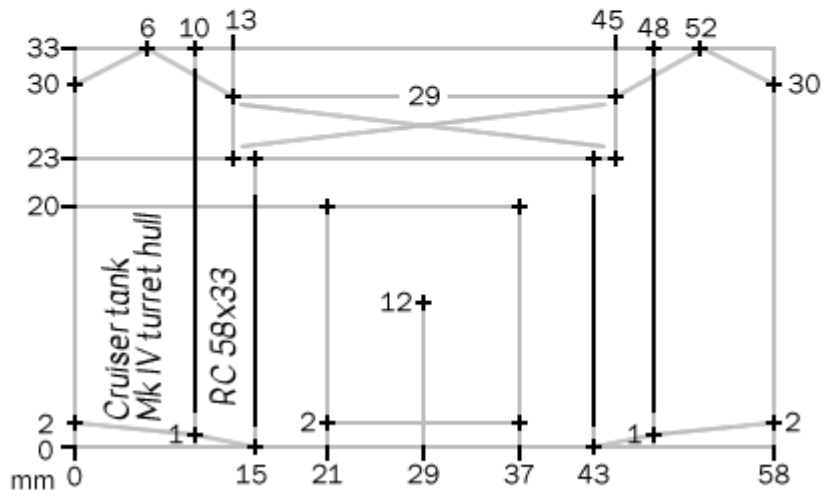
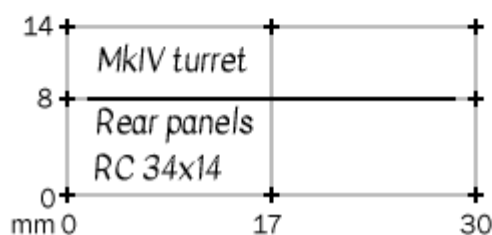
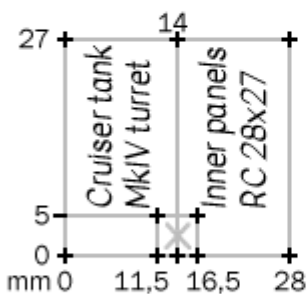

Diagrams on this page are not all at the same scale

## A20 Exhausts



(1) Roll a 18 x 12 mm piece of regular paper around a straightened piece of DWC wire, to obtain a  $\varnothing$  1,5 mm cylinder.  
 (2) Cut a 12 mm piece of DWC wire.

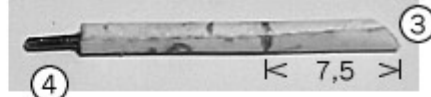

(3) The end of the spiral on the cylinder is to be the exhaust bottom. Cut one end at about 45°

(4) After the cut, insert the piece of DWC wire into the cylinder, push it 1 to 2 mm inside.

(5) Use the pliers to grab the assembly beyond the 7,5 mm line and bend it at a 90° angle.

(6) Note: the exhaust exit is part rearwards and part downwards.

(7) Mark the assembly 5,5 mm from the bottom, bend there at a 45° angle. Make several exhausts to match their lengths, paint separately.



## Part B - Cruiser Mk III & Mk IV turrets

Also including the CS (Close Support) barrel

### B01 Mk III turret

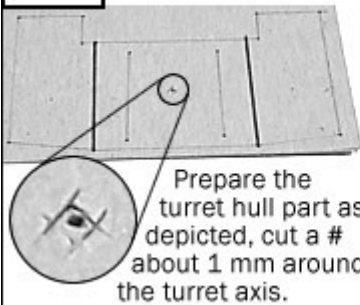

Prepare the turret hull part as depicted, cut a # about 1 mm around the turret axis.

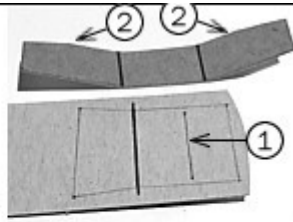

Prepare the "turret top" and "turret core" parts. (1) is a positioning line.

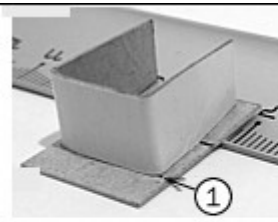

Glue the "turret core" to the "turret top" and "turret core" parts so that the bends (2) are on the folding line. Use layers of cardboard (or here, a ruler) to raise the front part. Let the glue harden.

Use a toothpick to perforate the turret axis so that the extruded material is inside the turret.

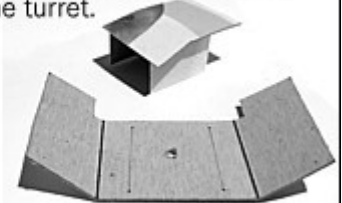

### B02 Mk III turret assembly



Glue the top assembly to the turret hull, using its positioning lines.  
 (1) Make sure that the rear wings of the hull are aligned with the rear of the top assembly.  
 (2) Exert downward pressure to the hull wings so that the corners are against the bottom. **Hold until the glue has hardened.**



Avoid this! →

Once the glue is completely dry, use nail scissors to trim the excess.



### B03 Mantlet core

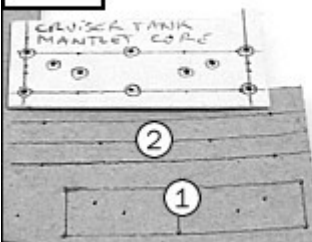

Use the same "Mantlet core" template to create the central parts (1) and the wings (2). For the wings, use the L or the S compasses to draw  $\varnothing$  6 mm circles. Draw a line 4 mm from the circle axis then cut off the part there.

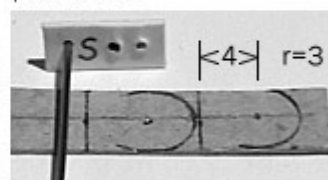

Perforate the holes of the central parts with the  $\varnothing$  0,6 mm pin. Cut and fold a 14 x 2 mm strip of cardboard as depicted. Glue this spacer, leave the holes free.

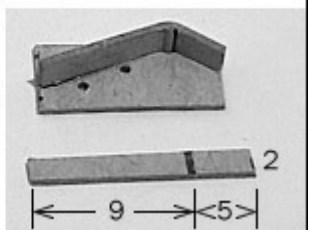

### B04 Mantlet core

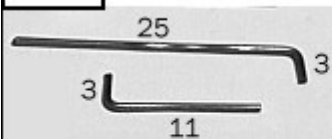

Gun wire: 28 mm of DWC wire, bend 3 mm.  
 Machinegun wire: 14 mm of DWC wire, bend 3 mm.



Slide the central parts onto the gun wire, glue them together. Once the glue is hard, glue the wings to it, make sure the machinegun hole is correct (see Step B05).

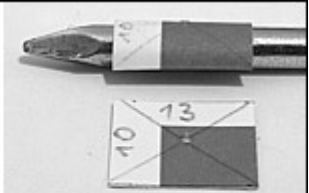

The mantlet in itself is made from a 13 x 10 mm piece of rigid paper, perforated in its center and given a round shape. The  $\varnothing$  3,6 mm nail (see Step T02) can be used for this.

### B05 Mantlet assembly



(1) Slide the mantlet part onto the gun wire, apply glue on the wings, glue the mantlet to the mantlet core.  
 (2) Perforate the machinegun hole from behind, making sure it is parallel to the gun wire. (3) Glue thin Kraft paper to the back to keep the wires in place.

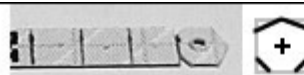
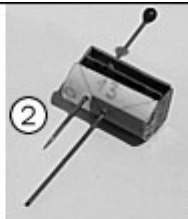

Make a strip with 3x3 mm squares of rigid paper. Perforate with the  $\varnothing$  0,6 mm pin and cut as depicted. Slide on the gun wire, glue to the mantlet.



(4) An X locates the bottom of the turret front panel. First insert the mantlet core (without glueing), then glue the front panel to the turret.



### B06



(1) Apply glue to the sides of the front panel opening. Grab the gun wire and pull the assembly to make contact with the front panel.

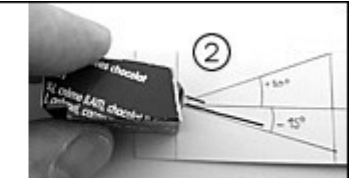
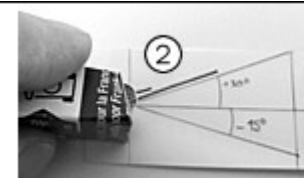

(2) The elevation of the gun can be set at this stage. Notice the jig is centered on the mantlet "wing" circle.

### B07 Gun barrels



(1) The barrel of the 2-pdr main gun is a  $\varnothing$  1,5 mm cylinder. Roll a 22 x 10 mm piece of regular paper around a straight piece of DWC wire. Slide onto the gun wire, with the seam downwards.

For the machine gun water jacket, cut 4 mm of Q-tip stem at an angle as depicted below. Apply glue to the angled portion and slide onto the wire.

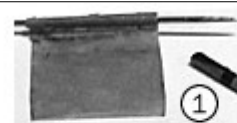
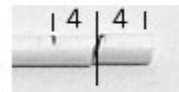

For the machine gun muzzle (1), glue a piece of Think Kraft Paper around the thin pin, until you have two thicknesses of paper. Remove the pin, when the glue is hard cut a 1 mm slice of that tube.

For the muzzle cover (2), glue a 9 x 9 mm piece of regular paper around a toothpick, remove the tube, cut a 1 mm slice. (3) Flatten the slice, cut 1 mm from the fold. Give the part a round shape.

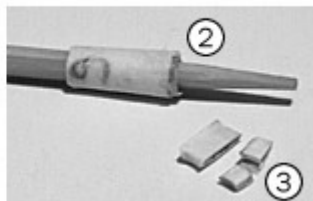

Apply glue on the Q-tip then glue the elements as depicted.



### B08 Turret assembly

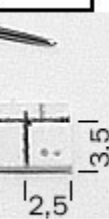

**Gunner vision port:** perforate the bottom of a 3,5 x 2,5 mm piece of cardboard as depicted. Cut between the two perforations, smooth the sides with the thin pin.



Trim the excess from the turret front panel. Glue the gunner vision port as depicted (the slit is the same height as the gun). (1) Glue a piece of cardboard 9 mm high and at least 27 mm wide to the rear of the turret. When the glue has hardened, trim the excess.

Apply glue on the top of the turret, position the "turret paper" using the folding line (2) and the guide lines (3).



### B09 Turret details

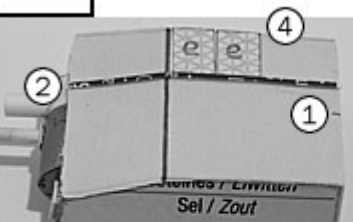

(1) Draw a mark at the middle of the turret rear.  
 (2) Cut a 0,5 mm strip of cardboard at least 30 mm long, glue it on this line.

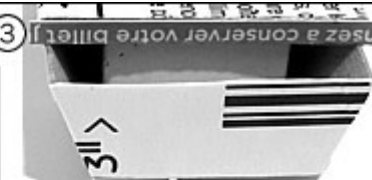

(3) Glue a 28 x 2 mm strip of rigid paper to the lower turret rear. Trim the excess.

(4) Use the "turret paper" template to make two "e" hatches from regular paper. Glue one close to the fold, the other with a slightly visible gap.

(4) With the same template, make two cardboard parts, with a 1 mm gap in the center. (5) Cut the edges of the parts, glue them on the external limits of the paper hatches.

The (1) mark is used for the radio bracket (see step B09).

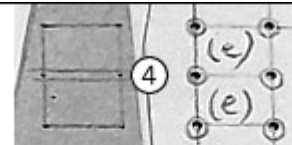

**B10** Use the template to make a pair of radio brackets.

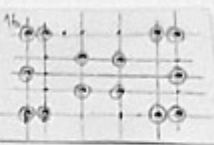

Cut and fold the bracket as depicted. It is glued directly to the turret rear, flush with the turret top.

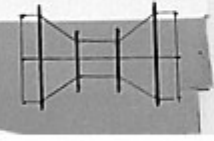

Perforate the turret rear below the antenna bracket with a thin pin. The hole is not in the middle, but 1 mm from the bracket left side.

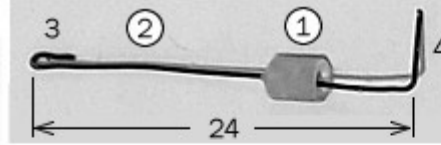
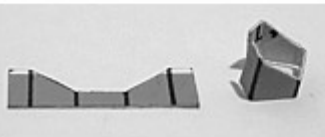

(1) Cut a 3 mm segment of Q-tip stem and push its center with a nail. Paint separately.

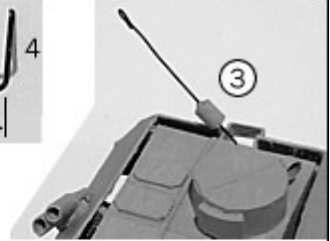

(2) Cut 32 mm of thin wire, bend one end into a 3 mm loop. After the Q-tip has been painted, insert it on the thin wire then bend 4 mm on the other end.

(3) Insert the 4 mm part behind the turret, glue the Q-tip to the left corner of the radio bracket.

**Pennants:** draw a 40x14 mm piece of kraft or regular paper as depicted (4). Fold, insert DWC wire in the fold, glue the sides together (5). Remove the wire, place a 2 mm marker and cut. Insert wire for painting.



**B11** The Mk III turret has an **octagonal cupola**. Cut and fold a 32 x 4 mm strip of regular cardboard as shown below. (1) Glue a 8 x 4 mm strip of thin kraft paper to one end. (2) Wait until the glue has hardened to glue the other half and close the shape.

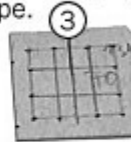
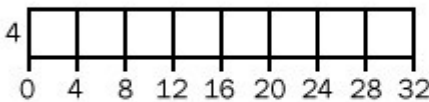

The dots on the "Mk III cupola top" part are for positioning, except the central line (3) which has to be cut into a slit, without cutting the part in two.



(4) Turn the part over and roll over the slit with a pen (shown halfway here).

(5) Glue the octagon to the cupola top part. When the glue has hardened, trim the excess.



**B12** Cupolas on the Mk III and Mk IV were able to rotate by themselves. In this design, they don't have this capability, they are glued in place instead.

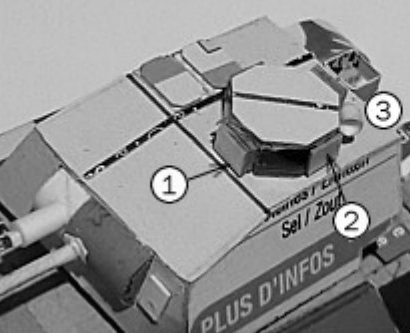

Notice the position of the cupola relative to the turret and the orientation of the slit between the cupola top hatches.

(1) The two main observation ports (forwards and rearwards) are made from three layers of cardboard cut at a dimension of 4 x 3 mm. Don't align these parts to the bottom of the cupola, leave some space between them and the turret top.

(2) Lateral observation ports: 4x3 mm pieces of cardboard (single layer).

(3) The searchlight is a 1,5 mm to 2 mm slice of Q-tip stem. Use the tip of a nail to push it into shape (4), then glue it as depicted.

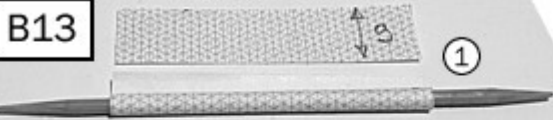

For the twin 4" Smoke Generator roll and glue a 9 mm strip of regular paper (1) around a toothpick to obtain a Ø 2 mm tube.

Cut the end bits of a toothpick of the same kind used to make the tube. It should be 1 mm wide. Cut 7 mm to get a cone.

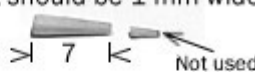

(4) Cut a 5 mm segment from the paper tube, apply glue inside one end and insert the toothpick cone up to the marking.



(5) Glue a 3x1 mm "spacer" piece of cardboard to a side of this smoke generator.

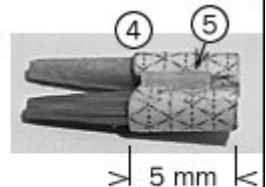

(2) Note: use a different blade to cut toothpicks than the one you use for paper.

(3) Make a mark at 5 mm from the tip of the cone.

Glue centered below the turret top's fold line, at an angle about 30° from the horizontal. The top of the tubes are at the level of the turret's top.

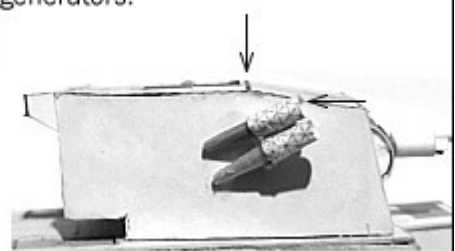

## Part C - Cruiser Mk IV turret

**C01** The Mk IV turret was a Mk III turret with spaced armour. In this design we will follow a build order similar to the Mk III turret, but with some differences.

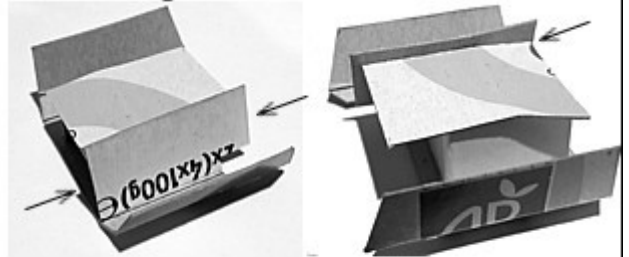
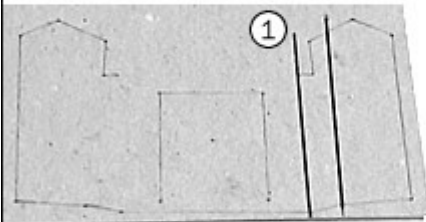

(1) There two fold lines on each side. (2) When gluing the top assembly **make sure** that the hull sides and the front of the assembly are aligned. **Do not glue** the hull sides.

The "inner panels" are like false Mk III turret sides. Apply glue on their lower side and on the side of the turret top, glue them like the sides on the Mk III.

**C02** First glue & trim the "Turret paper top" like on the Mk III, mark the middle of the rear of the top panel.

### Mk IV side spacers

Glue two pieces of cardboard of different heights together.

3 mm  
4 mm

Cut several pieces of it, about 1 mm wide, until you have four pieces with identical width.

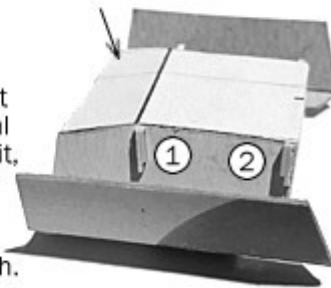

Both sides of the spacers are porous. Glue the spacers on their side as depicted. On each side, one spacer is glued before the paper top's fold line (1), the other at the rear of the inner panel (2). Both are flush with the turret top.

Glue the hull sides to the top of the spacers, flush with the top, until the glue has hardened.



**C03** Glue the radio bracket and prepare the two "rear panels". When the glue for the radio bracket has hardened, apply glue on one of its side and on the rear of the hull side across. Place one of the rear panel and **hold it place until the glue has hardened**, without damaging the radio bracket.



Make sure the rear panel is parallel with the rear of the turret top. After the second panel is in place, trim the excess.

**C04** (1) On the Mk IV turret the front panel cannot be trimmed after gluing. Measure the height, cut small trimmings (alternate between top and bottom) until the part fits. For the "lower turret rear" panel (see B09 page 12) use a 34 mm x 3 strip of rigid paper.

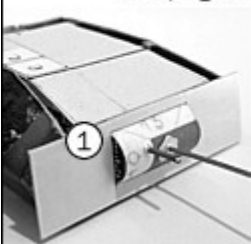

Mk IV **mantlet spaced armour** (continued on Step F01 page 16). Use the specific template on the porous surface of the "turret front" panel (2).

Flip the template over (3), draw the central dots on the porous side of a piece of cardboard. Trim to 10x6 mm as depicted.

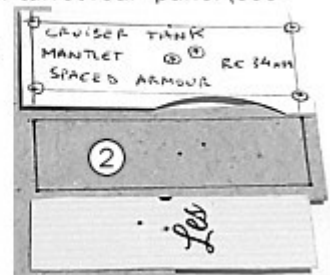
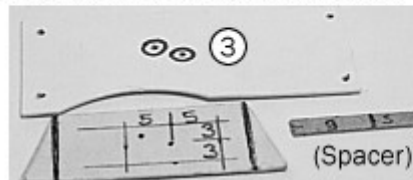

**C05** The Mk IV turret has a  $\varnothing$  10 mm x 4 mm **cylindrical cupola**.

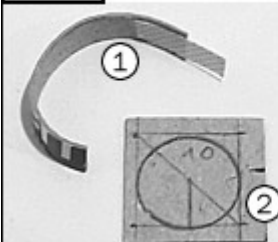

(1) Cut a 31 x 4 mm piece of cardboard, give it a round shape then glue a piece of regular paper one one end. When the glue has dried, glue the other to close the shape.

(2) For the cupola top, draw a  $\varnothing$  10 mm circle inside a 10 mm square. Pay close attention to the direction of the diagonal and the positioning segment. Cut the diagonal like on Step B11.

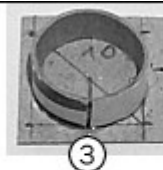

(3) Glue the cylinder to the top so the positioning segment and the seam are aligned.



(4) For each of the two observation ports, cut two 5 x 3 mm pieces of cardboard and give them a round shape. Notice the seam is at the rear.

## Part D - Cruiser Mk III & Mk IV running gear

Road wheels, idler, sprocket, tracks.

### D01 Road wheels

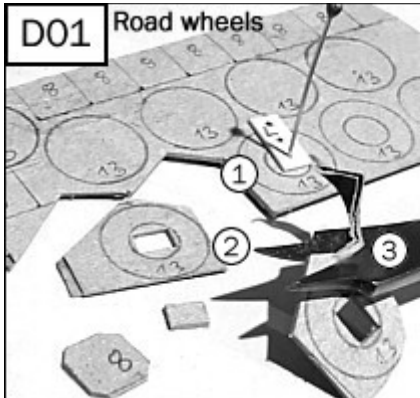

Glue two large pieces of regular cardboard together. (1) Use the "L" compass to draw  $\varnothing 13$  mm circles. On half of the circles, also draw  $\varnothing 6$  mm circles. (2) Use the  $\varnothing 6$  mm circles to cut a hole out. (3) Use nail scissors to cut the disks. (4) Also cut out 8 mm squares from the same material, cut off the corners as depicted.



Glue the smooth side of a part to the porous side of the next part. Align the disk one to the other.

There are eight road wheels, thus 16 spacers, 8 full disks and 8 disks with a hole.

**Note:** it is important to use the same material for all the road wheels, spacers and sprocket wheels.

### D02 Road wheel covers

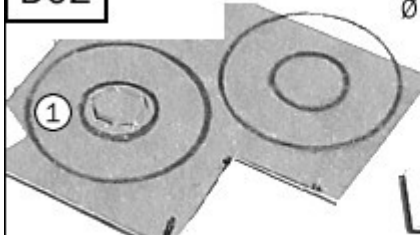

(1) Cut an octagonal shape inside the  $\varnothing 4$  mm circle, close to the line. (2) Push a  $\varnothing 3,6$  mm cylinder through the octagonal opening.

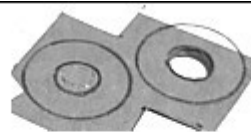

This part is very visible, discard it if the hole is not well centered.

Use the "M" compass to draw  $\varnothing 10$  mm and  $\varnothing 4$  mm circles on **rigid paper**.

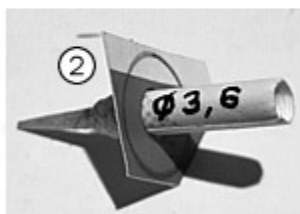

Optional: if you're using a 3,6 mm nail you may want to trim the extruded material with the utility knife as depicted.

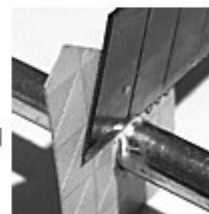

### D03



Cut out the **road wheel covers** with nail scissors. Stick them to adhesive tape for painting (see page 10).

Cut eight 1,5 mm slices of Q-tip stem, stick them to adhesive tape then push their center with a thin ball pen (1) to create a visually unified shape.

For the **idler wheels**, cut single-layer  $\varnothing 9$  mm disks separately and glue them together. Assemble like the road wheels (2), use 5 mm squares for spacers.



### D04 Sprocket wheels

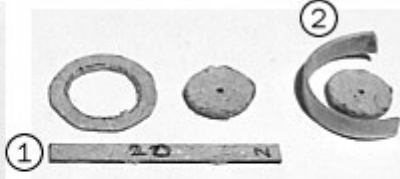
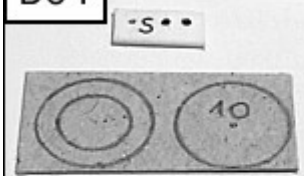

Use the "S" compass to create a regular  $\varnothing 10$  mm disk and a  $\varnothing 10$  mm disk with a concentric  $\varnothing 6$  mm disk. Cut out the  $\varnothing 6$  mm disk and keep it. Cut a 20x2 mm piece of cardboard (1), give it a round shape (2) then glue it around the  $\varnothing 6$  mm disk so that the disk is at middle height (neither on the top nor on the bottom).

Glue the cylinder to the  $\varnothing 10$  mm disk, glue the ring shape on top. Notice you can pierce a motif with the tip of a pin.

Glue two 6 mm squares of regular cardboard to the rear as spacers.

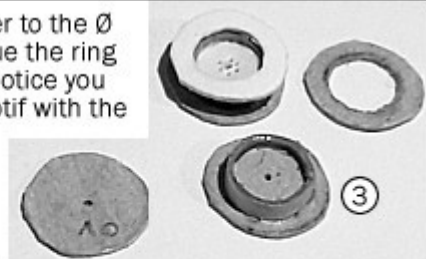

### D05 The template for the tracks allows to make two pairs at once.

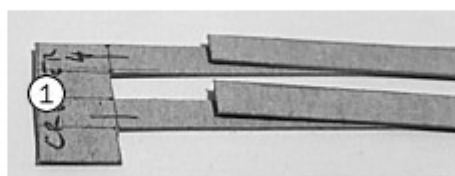
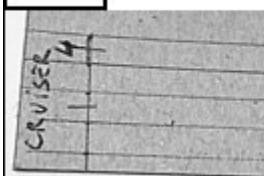

Mark every other track and cut as depicted. The bridge between the tracks (1) gives a good grip for painting and allows to suspend the tracks for drying.



## Part E - Assembly after painting

### Part F - Special version - Mk IV turret with mantlet spaced armour

**E01** **Glue the wheels to the hull** so that their edge is located just over the positioning dot (1). Do not glue the "road wheel covers" at this stage (see step E02).

Position the tracks, give them a round shape where they would wrap around the idler and the sprocket.



Apply glue to the top of the road wheels, press the tracks against it. You may want to use toothpicks to spread out the pressure.

The road wheels and the tracks are covered with paint, glue will take a lot of time to harden. It is not necessary to apply glue to the idlers and sprockets.

Apply glue below the rear road wheels, hold the tracks in place over the top of the road wheels while positioning them.

You may want to hold the tracks on top of the road wheel and underneath it at the same time.

(2) Position the second end of the tracks under the first end, mark the limit and trim, then glue the tracks.

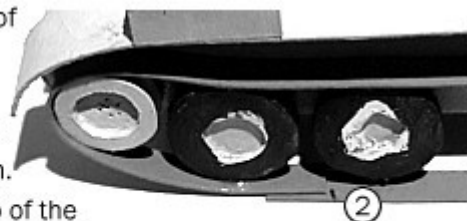

**E02** **Sand shields:** first make measurements without glueing. (1) The sand shield is aligned to the central part of the mudguard. (2) Mark the end of the mudguard, connect it to the point (3), remove what is below. (4) Cut a round edge, about 2 mm in radius. (5) Make sure the two side shields are mirrored (one for each side) before painting them.

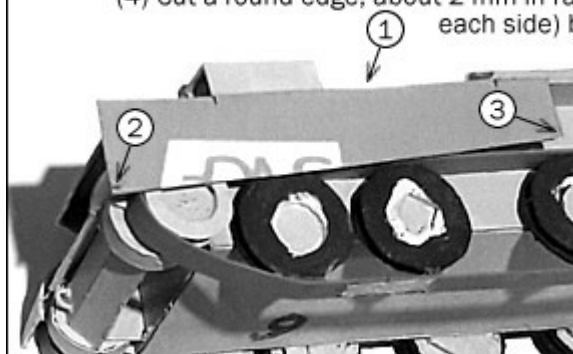

Paint the parts. While the paint dries, glue the road wheel covers (6). When the paint has dried, glue the shields to the mudguards. Trim them after the glue has hardened.

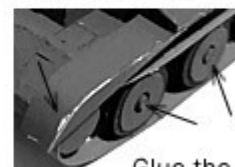

Glue the Q-tip slices, touch up with paint after trimming.

**E03** **Last step: glueing the exhausts.** Apply glue generously on the last bit of the exhausts, as well as on the inner

wall of the "exhaust side" parts. Turn the hull upside down, install the exhausts, make sure they are perpendicular to the mudguards.



**F01** **Mk IV Mantlet Spaced Armour** (Continued from C04 p. 14)

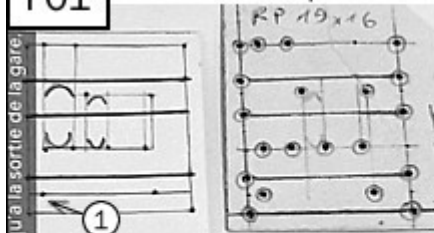

Use the template to draw the rigid paper part. Notice that the two slits on the right are drawn based on two dots. (1) is a positioning line.

Use the same wire components as on Step B04. Insert them before glueing the two panels together so that the barrels follow the same angle as the turret front.

The barrels are 3 mm longer: the gun barrel is 25 mm long, the MG water jacket is 7 mm long. (2) Cut out the slits, fold.

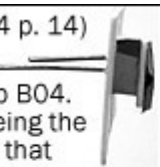

(3) Insert & glue the barrels. Glue the armour underneath the turret, use line (1).

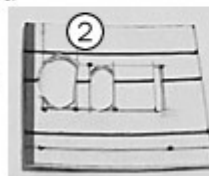

(4) Glue the armour top so that the front is vertical. Glue rigid paper to the sides, trim the excess.

